



4.5 CU FT DIAMOND COMPACT REFRIGERATOR

INSTALLATION & OPERATION INSTRUCTIONS

*Read all instructions before you operate your Diamond Compact Refrigerator.
Save these instructions!*

www.diamondgrillsbbq.com

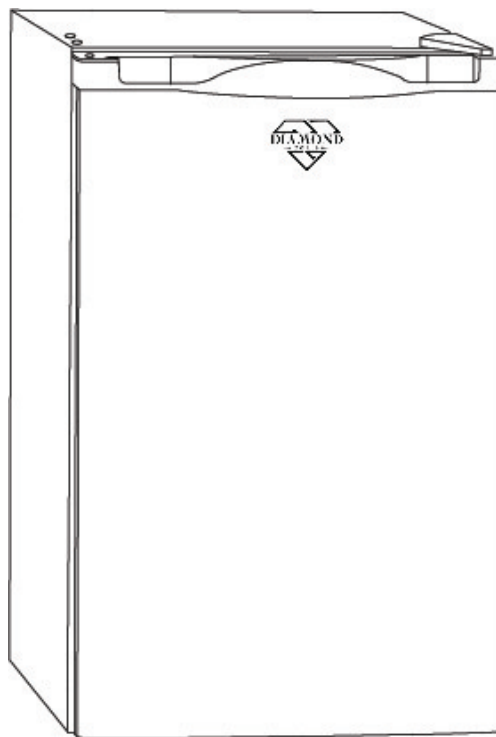

CERTIFIED TO:
3114139

Model: DG-R20

TO INSTALLER: Leave this manual with the Diamond Compact Refrigerator.
TO CONSUMER: Keep this manual for future reference.



DANGER:

Plug into a grounded 3-prong outlet, do not remove grounding prong, do not use an adapter, and do not use, an extension cord.



DANGER:

It is recommended that a separate circuit, serving only your refrigerator be provided. Use receptacles that cannot be turned off by a switch or pull chain.



THIS IS A SAFETY ALERT SYMBOL

This symbol alerts you to potential hazards that can kill or injure you and others. All safety messages will follow the Safety Alert Symbol and either the words: “DANGER”, “WARNING”, or “CAUTION”.



DANGER:

Never clean refrigerator parts with flammable fluids. These fumes can create a fire hazard or explosion. Do not store or use gasoline or other flammable vapors and liquids in the vicinity of this or any other appliance.



DANGER:

Before proceeding with cleaning and maintenance operations, make sure the power line of the unit is disconnected.



DANGER:

Do not connect or disconnect the electric plug when your hands are wet.



DANGER:

Unplug the refrigerator or disconnect power before cleaning or servicing. Failure to do so can result in electrical shock or death.



DANGER:

Do not attempt to repair or replace any part of your refrigerator unless it is specifically recommended in this manual. All other servicing should be referred to a qualified technician.



WARNING:

Use two or more people to move and install refrigerator. Failure to do so can result in back or other injury

**WARNING:**

To ensure proper ventilation for your refrigerator, the front of the unit must be completely unobstructed. Choose a well-ventilated area with temperatures above 60°F (16°C) and below 90°F (32°C). This unit must be installed in an area protected from the element, such as wind, rain, water spray or drips.

**WARNING:**

The refrigerator must be installed with all electrical, water and drain connections in accordance with state and local codes. A standard electrical supply (115 V AC only, 60 Hz), properly grounded in accordance with the National Electrical Code and local codes and ordinances is required.

**WARNING:**

Do not kink or pinch the power supply cord of refrigerator

**WARNING:**

The fuse (or circuit breaker) size should be 15 amps.

**WARNING:**

It is important for the refrigerator to be leveled in order to work properly. You may need to make several adjustments to level it.

**WARNING:**

All installation must be in accordance with local plumbing code requirements.

**WARNING:**

Make certain that the pipes are not pinched or kinked or damaged during installations.

**WARNING:**

Check for leaks after connection

**WARNING:**

Never allow children to operate, play with or crawl inside the refrigerator.

**WARNING:**

Do not use solvent-based cleaning agents or abrasives on the interior. These cleaners may damage or discolor the interior.

**WARNING:**

Do not use this apparatus for other than its intended purpose.

**WARNING:**

Keep ventilation openings, in the appliance enclosure or in the built-in structure, clear of obstruction.

**WARNING:**

Do not use mechanical devices or other means to accelerate the defrosting process, other than those recommended by the manufacturer.

**WARNING:**

Do not damage the refrigerant circuit.

**WARNING:**

Do not use electrical appliances inside the food storage compartments of the appliance, unless they are of the type recommended by the manufacturer.

IMPORTANT SAFETY INFORMATION FOR INSTALLERS:

Leave this manual with the end-user and instruct them to retain it for future reference. Instructions and product updates are also available at www.diamondgrillsbbq.com under the MANUALS AND CERTIFICATES tab.

IMPORTANT SAFETY INFORMATION FOR END USERS:

Read all instructions before using the refrigerator. Child entrapment and suffocation are not problems of the past. Junked or abandoned refrigerators are still dangerous. . . even if they will “just sit in the garage a few days.” Before you throw away your old refrigerator: Take off the doors. Leave the shelves in place so that children may not easily climb inside. Never allow children to operate, play with, or crawl inside the refrigerator. Never clean refrigerator parts with flammable fluids. The fumes can create a fire hazard or explosion. Do not store or use gasoline or any other flammable vapors and liquids in the vicinity of this or any other refrigerator. The fumes can create a fire hazard or explosion.

TABLE OF CONTENTS

SAFETY

<i>Warning Labels & Symbols</i>	002
<i>Important Safety Instructions</i>	005

REFRIGERATOR INFORMATION

<i>Parts and Features</i>	007
<i>Product Dimensions</i>	008

REFRIGERATOR INSTALLATION

<i>Before Using Your Unit</i>	009
<i>Installing Your Unit</i>	009
<i>Electrical Connection</i>	010
<i>Wiring Diagram</i>	011
<i>Extension Cord</i>	012
<i>Reversing the Door Swing of Your Appliance</i>	012

REFRIGERATOR OPERATION

<i>Setting the Temperature Control</i>	014
--	-----

REFRIGERATOR PERFORMANCE

<i>Care and Maintenance</i>	015
<i>Troubleshooting</i>	017

WARRANTY & SUPPORT

<i>Warranty Information</i>	018
<i>Customer Support</i>	019

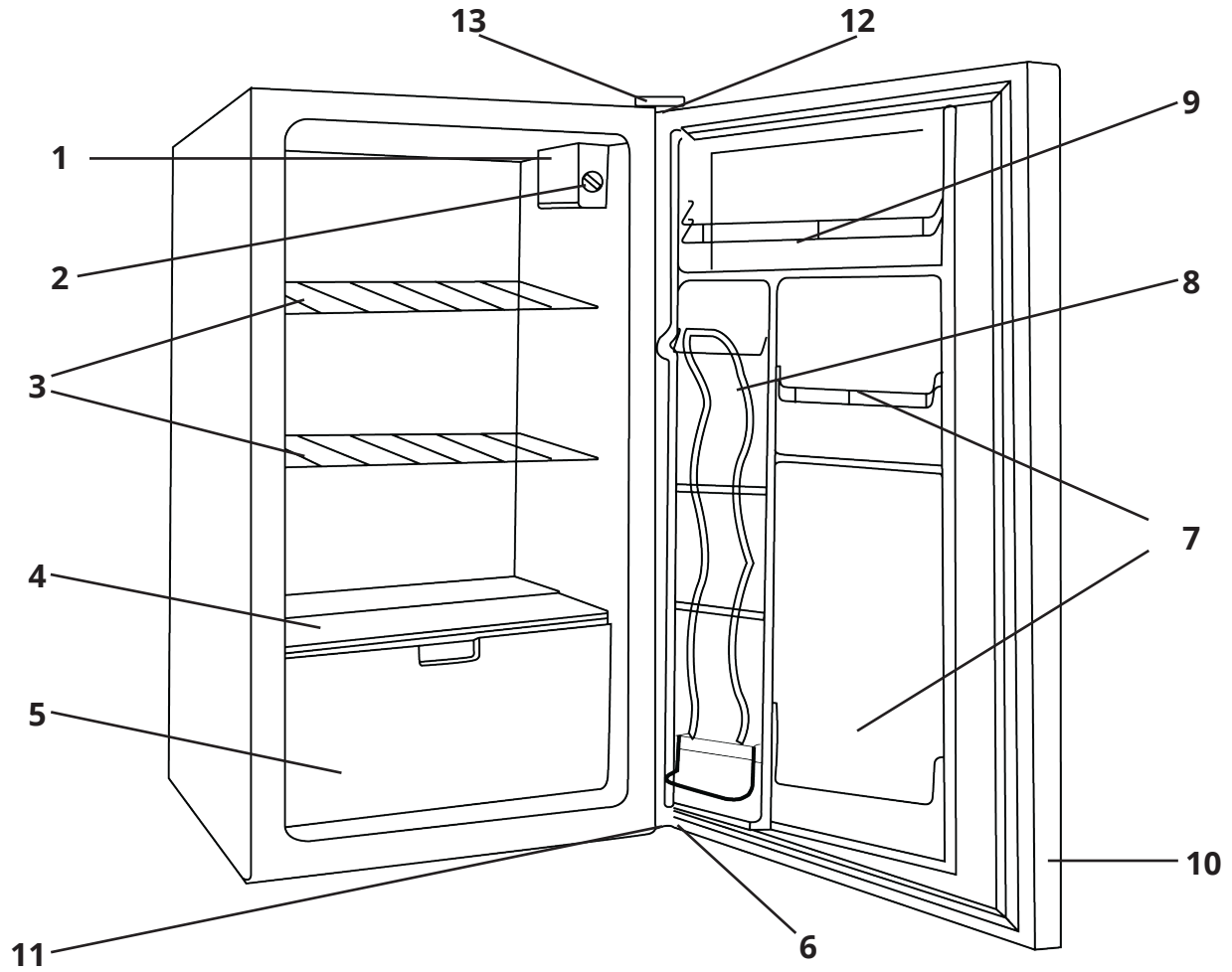

PARTS

1. Interior Light Cover
2. Temperature Control Knob
3. Shelves (Wire)
4. Glass Shelf
5. Drawer
6. Leveling Leg
7. Door Bar (2)
8. Can Dispenser
9. Condiment Bar
10. Door
11. Bottom Hinge
12. Top Hinge
13. Top Hinge Cover

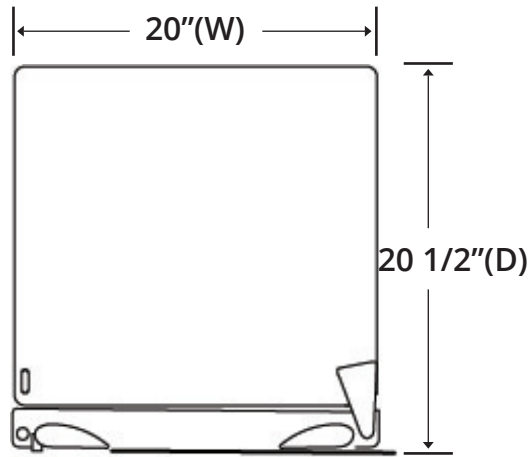

TOP VIEW

DIAMOND COMPACT REFRIGERATOR 4.5 Cubic Feet	
PACKAGING SIZE	21.73"(W) × 22.52"(D) × 33.66"(H)
GROSS WEIGHT	66 lbs
CERTIFICATION	
ETL APPROVED	

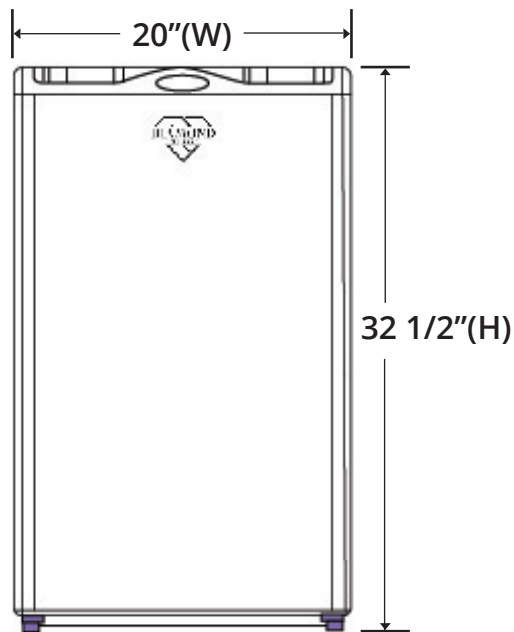

FRONT VIEW

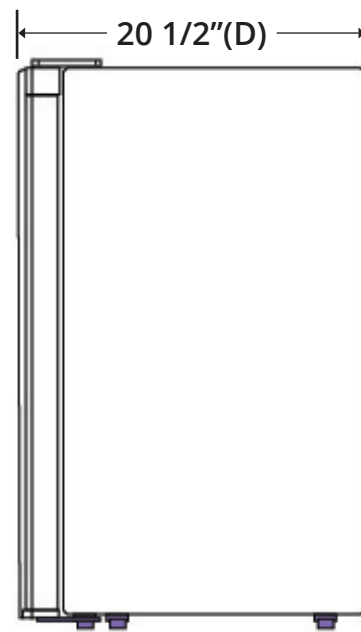

RIGHT SIDE VIEW

INSTALLATION INSTRUCTIONS

Before Using Your Unit

- Remove the exterior and interior packing.
- Check to be sure you have all of the following parts:
 - 2 Shelves
 - 1 Glass Lid
 - 1 Crisper
 - 1 Instruction Manual
- Before connecting the unit to the power source, let it stand upright for approximately 2 hours. This will reduce the possibility of a malfunction in the cooling system from handling during transportation.
- Clean the interior surface with lukewarm water using a soft cloth.

Installing Your Unit

- This appliance is designed to be free standing only, and should not be recessed or built-in.
- Place your unit on a floor that is strong enough to support the unit when it is fully loaded. To level your unit, adjust the two leveling legs at the bottom of the unit.
- Locate the unit away from direct sunlight and sources of heat (stove, heater, radiator, etc.). Direct sunlight may affect the acrylic coating and heat sources may increase electrical consumption. Extreme cold ambient temperatures may also cause the unit not to perform properly.
- Avoid placing the unit in moist areas.
- Plug the unit into an exclusive, properly installed-grounded wall outlet. Do not under any circumstances cut or remove the third (ground) prong from the power cord. Any questions concerning power and/or grounding should be directed toward a certified electrician or an authorized Products service center.
- After plugging the appliance into a wall outlet, allow the unit to cool down for 2-3 hours before placing food in the refrigerator compartment.

Electrical Connection



WARNING:

Improper use of the grounded plug can result in the risk of electrical shock. If the power cord is damaged, have it replaced by an authorized service center.

This unit should be properly grounded for your safety. The power cord of this unit is equipped with a three-prong plug which mates with standard three prong wall outlets to minimize the possibility of electrical shock.

Do not under any circumstances cut or remove the third ground prong from the power cord supplied. For personal safety, this appliance must be properly grounded.

This unit requires a standard 115 Volt AC /60Hz electrical outlet with three-prong ground. Have the wall outlet and circuit checked by a qualified electrician to make sure the outlet is properly grounded. When a standard 2-prong wall outlet is encountered, it is your responsibility and obligation to have it replaced with a properly grounded 3-prong wall outlet.

The cord should be secured behind the unit and not left exposed or dangling to prevent accidental injury.

The unit should always be plugged into its own individual electrical outlet which has a voltage rating that matches the rating label on the appliance. This provides the best performance and also prevent overloading house wiring circuits that could cause a fire hazard from overheating. Never unplug the unit by pulling the power cord. Always grip the plug firmly and pull straight out from the receptacle. Repair or replace immediately all power cords that have become frayed or otherwise damaged. Do not use a cord that shows cracks or abrasion damage along its length or at either end. When moving the unit, be careful not to damage the power cord.

WIRING DIAGRAM

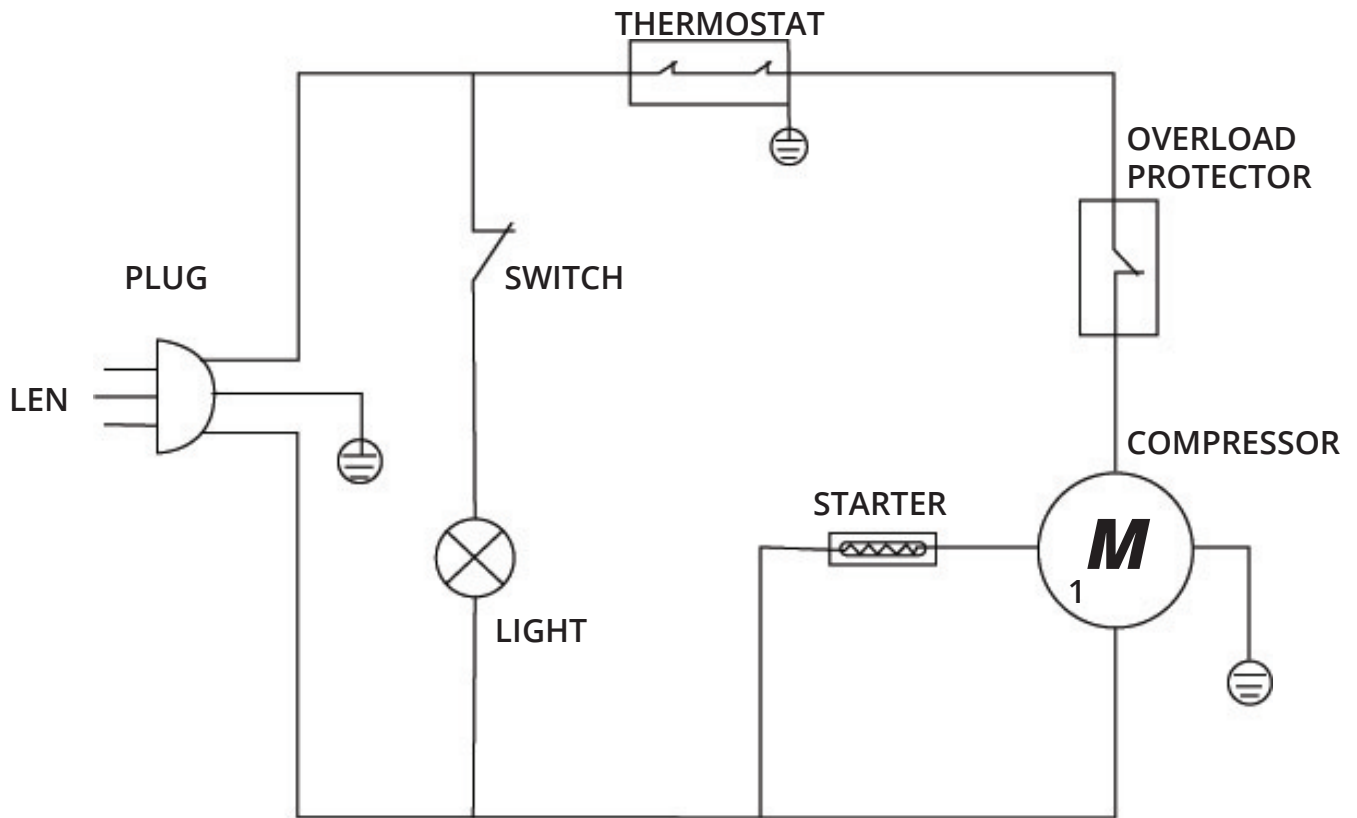

Extension Cord

Because of potential safety hazards under certain conditions, it is strongly recommended that you do not use an extension cord with this unit. However, if you must use an extension cord it is absolutely necessary that it be a 3-wire grounding type appliance extension cord having a grounding type plug and outlet and that the electrical rating of the cord be 220 volts and at least 15 amperes.

Reversing the Door Swing of Your Appliance

This refrigerator can be opened either from the left or right side. The default way of opening the door is from the right side. If you want to open the door from the left side, please follow the instructions below.

NOTE:

All the removed parts must be well kept for the reinstallation of the door.

- Remove the three screws (6) that hold the lower door hinge (5), keep the hinge for later use.
- Remove the door from the upper pin (3), and keep the padded surface upwards to prevent the scratching.
- Remove the upper hinge cover (1), remove the two screw (2), hold the upper hinge(3), save the hinge for later use.
- Remove the hole cover (1) and transfer it to the same location on the opposite side.

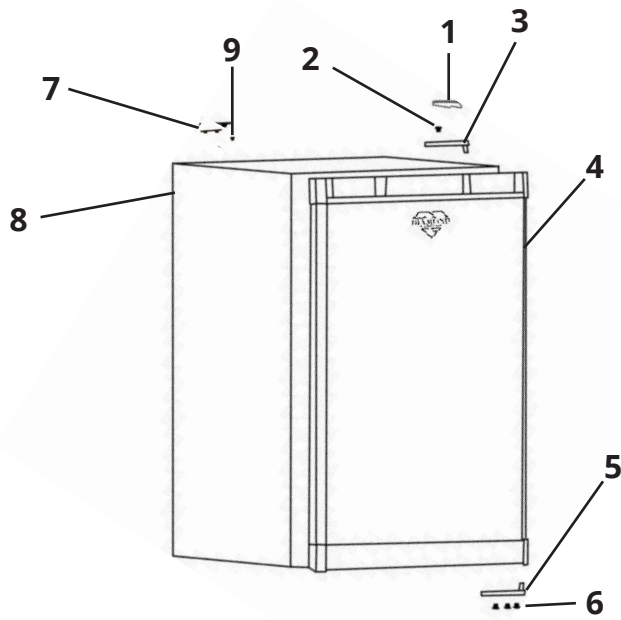

FIGURE 1 (Normal Position)

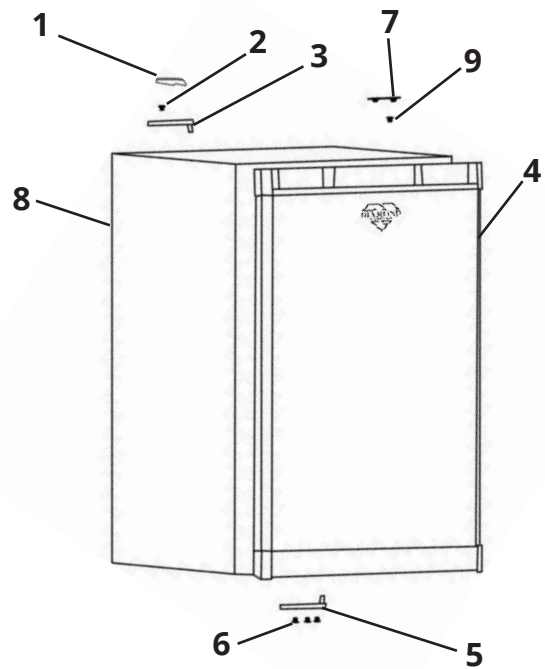

FIGURE 2 (Position after door reversal)

PARTS

1. Upper Hinge Cover
2. Screw
3. Upper Hinge
4. Door
5. Lower Door Hinge
6. Screw
7. Hole Cover
8. Cabinet
9. Pin Cap

- Insert the Lower Door Hinge in the right side, fix the lower right hinge by tightening all the screws.
- Remove the Pin Cap (9) from the right side of the upper frame of the door, and then transfer it to the same location on the opposite side.
- Put the door on the Lower Door Hinge(5), keep the door level , and then fix the upper hinge(3) to the body(4) by the screws.
- Put on the Upper Hinge Cover.

Setting the Temperature Control

- Your unit has only one control for regulating the temperature in the compartment. The temperature control is located on the upper right hand side of the compartment.
- The first time you turn the unit on, set the temperature control to "6".
- The range of the temperature control is from position "OFF" to "6". After 24 to 48 hours, adjust the temperature control to the setting that best suites your needs. The setting of "3" should be appropriate for home or office use.
- To turn the appliance off, turn the temperature control to "OFF".

NOTE:

- Turning the temperature control to "OFF" position stops the cooling cycle but does not shut off the power to the unit.
- If the unit is unplugged, has lost power, or is turned off, you must wait 3 to 5 minutes before restarting the unit. If you attempt to restart before this time delay, the unit will not start.

CARE AND MAINTENANCE



CAUTION:

Do not use boiling water because it may damage the plastic parts. In addition, never use a sharp or metallic instrument to remove frost as it may damage the cooling system and will void the warranty. We recommend using a plastic scraper.

Cleaning Your Unit

- Turn the temperature control to “OFF”, unplug the unit, and remove the food, shelf, and tray.
- Wash the inside surfaces with a warm water and baking soda solution. The solution should be about 2 tablespoons of baking soda to a quart of water.
- Wash the shelf and tray with a mild detergent solution.
- The outside of the unit should be cleaned with mild detergent and warm water.
- Wash the outside cabinet with warm water and mild liquid detergent. Rinse well and wipe dry with a clean soft cloth.



CAUTION:

Failure to unplug the unit could result in electrical shock or personal injury.

Power Failure

- Most power failures are corrected within a few hours and should not affect the temperature of your unit if you minimize the number of times the door is opened. If the power is going to be off for a longer period of time, you need to take the proper steps to protect your food.

Vacation Time

- **Short vacations:** Leave the unit operating during vacations of less than three weeks.
- **Long vacations:** If the appliance will not be used for several months, remove all food and unplug the power cord. Clean and dry the interior thoroughly. To prevent odor and mold growth, leave the door open slightly: blocking it open if necessary.

Moving Your Unit

- Remove all the food.
- Securely tape down all loose items inside your unit.
- Turn the leveling legs up to the base to avoid damage.
- Tape the door shut.
- Be sure the unit stays secure in the upright position during transportation. Also protect the outside of unit with a blanket, or similar item.

Energy Saving Tips

- The unit should be located in the coolest area of the room, away from heat producing appliances, and out of the direct sunlight.
- Let hot foods cool to room temperature before placing in the unit. Overloading the unit forces the compressor to run longer.
- Be sure to wrap foods properly, and wipe containers dry before placing them in the unit. This cuts down on frost build-up inside the unit.
- Unit storage bin should not be lined with aluminum foil, wax paper, or paper toweling. Liners interfere with cold air circulation, making the unit less efficient.
- Organize and label food to reduce door openings and extended searches. Remove as many items as needed at one time, and close the door as soon as possible.

TROUBLESHOOTING

PROBLEM	SOLUTION
Unit does not operate.	<ul style="list-style-type: none"> -Not plugged in. -The circuit breaker tripped or there is a blown fuse. -The unit temperature control is set in the "OFF" position.
Turns on and off frequently.	<ul style="list-style-type: none"> -The room temperature is hotter than normal. -A large amount of food has been added to the unit. -The door is opened too often. -The door is not closed completely. -The temperature control is not set correctly. -The door gasket does not seal properly. -The clearance apart from other high heat appliances is less than 10 inches.
Unit is vibrating.	<ul style="list-style-type: none"> -Check to assure that the unit is level.
The unit seems to make too much noise.	<ul style="list-style-type: none"> -The rattling noise may come from the flow of the refrigerant, which is normal. -As each cycle ends, you may hear gurgling sounds caused by the flow of refrigerant in your unit. -Contraction and expansion of the inside walls may cause popping and crackling noises. -The unit is not level.
The door will not close properly.	<ul style="list-style-type: none"> -The unit is not level. -The door was reversed and not properly installed. -The gasket is dirty or bent. -The shelves, bins, or baskets are out of position.



DIAMOND GRILLS BBQ REFRIGERATOR - WARRANTY INFORMATION

DIAMOND GRILLS BBQ offers a warranty on refrigerators to the original purchaser with proof of purchase. Our products are guaranteed to be free from defects in both workmanship and materials for the specified periods below. This warranty is not applicable to refrigerators used in commercial or rental applications. Any issues related to rust, corrosion, oxidation, or discoloration due to moisture or overheating are not covered under this warranty, unless such issues render the affected component inoperable. Additionally, this warranty does not include labor or labor-related charges. If warranty parts need to be shipped, customers will be responsible for any associated shipping and handling fees. Thank you for choosing Diamond Grills BBQ.

ONE-YEAR WARRANTY:

Our obligation under this warranty is limited to repair or replacement, at our option, of the product during the warranty period. The extent of any liability of Diamond Grills BBQ, under the warranty is limited to repair or replacement. This warranty does not cover normal wear of parts or damage resulting from any of the following: negligent use or misuse of the product, use contrary to operating instructions, or alteration by any person other than our factory service center. The warranty period is not extended by such repair or replacement.

LIMITATIONS & EXCLUSIONS:

This warranty applies to refrigerators purchased and located in the United States and Canada. Coverage begins on the original purchase date and is valid only for the original purchaser. It does not cover refrigerators used in commercial or rental applications, and is intended for residential use only.

To activate the warranty, customers must register the product online at:

www.diamondgrillsbbq.com/warranty-and-policies/

Please note that this warranty does not cover damages resulting from negligence, alteration, misuse, abuse, accidents, natural disasters, loss of electrical power, improper installation or operation, unauthorized adjustments or calibrations, dings, dents, scratches, or damages caused by harsh cleaning chemicals. The warranty is not valid for commercial use or for products with altered or removed serial numbers. DIAMOND GRILLS BBQ will not be liable for any incidental, consequential, special, or contingent damages arising from the breach of this written warranty or any implied warranty.

WARRANTY CLAIM PROCEDURE:

Please contact DIAMOND GRILLS BBQ Warranty Service Center for factory direct assistance. We are open Monday-Friday 7am-5pm (PST)

Phone Number: (909) 460-5579

Email: support@diamondgrillsbbq.com

Refrigerator - Warranty

1-YEAR WARRANTY
Motor Fans Interior Lighting Control



SCAN TO
REGISTER
YOUR
PRODUCT
ONLINE



DIAMOND GRILLS BBQ

Contact Information:

Phone: (909) 460 - 5579

Sales: sales@diamondgrillsbbq.com

Support: support@diamondgrillsbbq.com

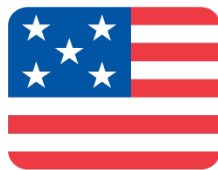

Designed and Engineered
IN THE USA