

## ***MOUNTING BRACKET***

**FOR CONCRETE BOWLS**

OPT-INBR

## SAFETY WARNINGS

### WARNING

Improper installation, adjustment, alteration, service or maintenance can cause injury or property damage. Read the installation, operating and maintenance instructions thoroughly before installing or servicing this equipment.

### WARNING

**California Proposition 65 Warning:** Chemicals known to the State of California to cause cancer, birth defects or other reproductive harm are found in and/or created by the combustion of natural gas, propane, butane and other fuels. Always operate this unit as described in the owner's manual and in well ventilated areas.

### WARNING

Do not use charcoal or other solid fuel in gas burning appliances.

Do not use your bowl for cooking.

Do not heat any unopened glass or metal container of food in the bowl.

Pressure may build up and cause the container to burst, possibly resulting in serious personal injury or damage to the bowl.

Never allow clothing or other flammable materials come in contact with any hot surface until it has fully cooled.

Never wear loose fitting or hanging garments while using your bowl. Fabric may ignite and result in personal injury.

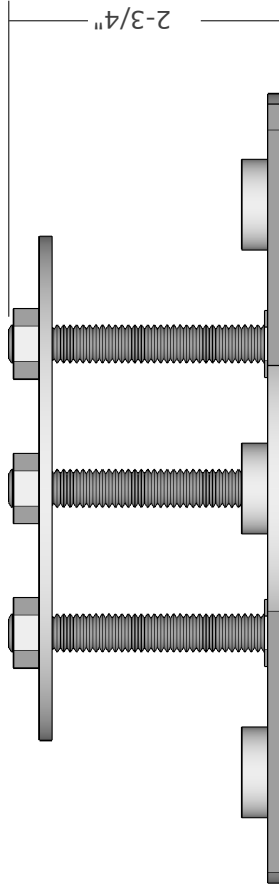
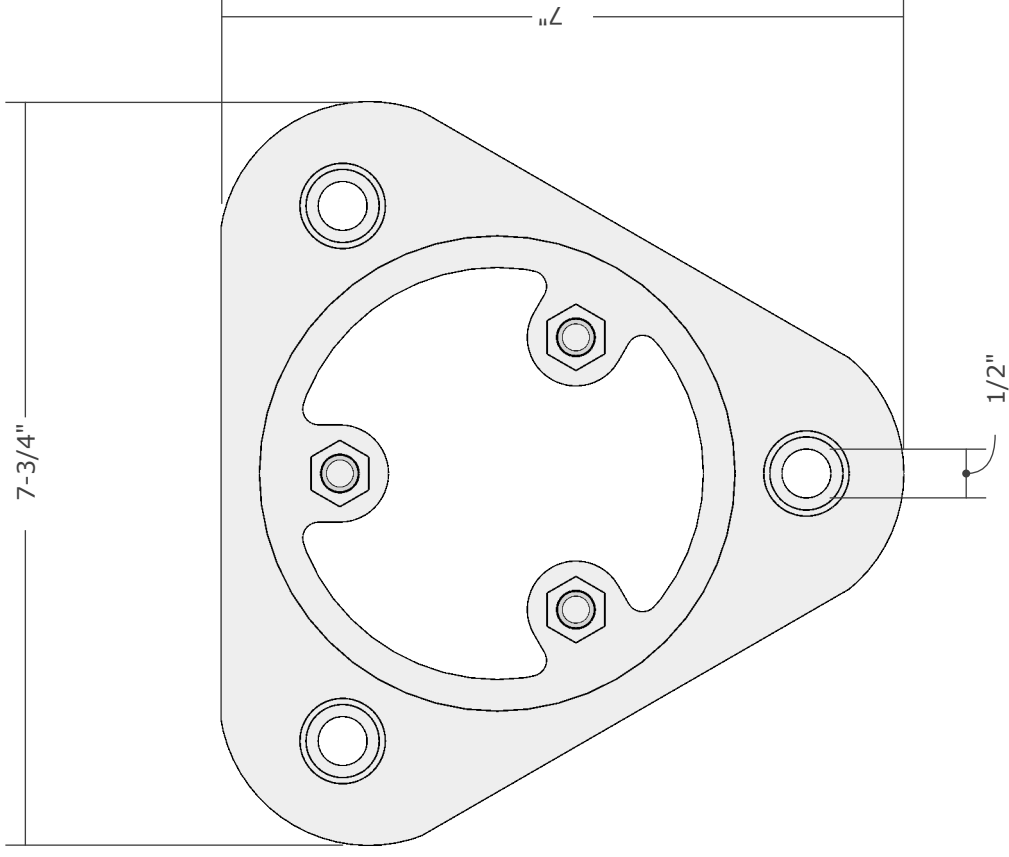
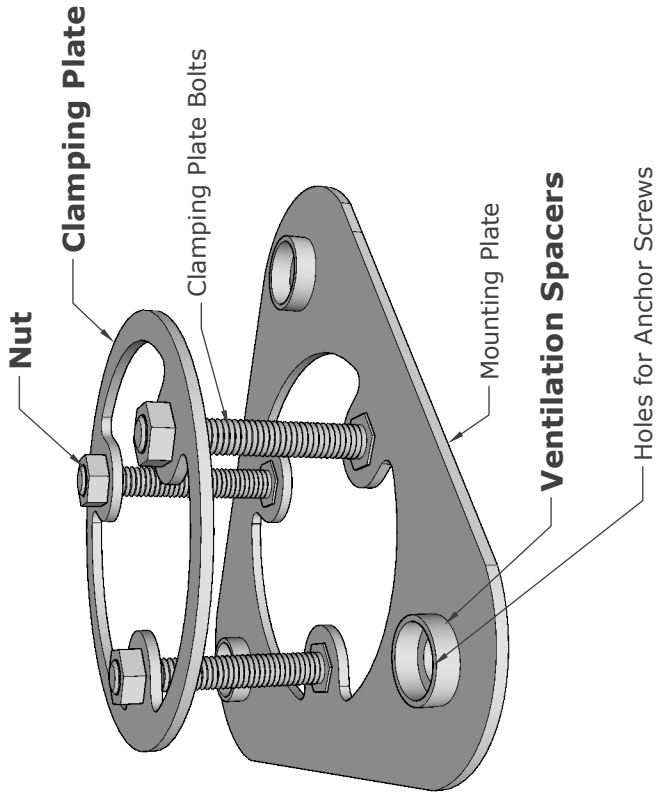

THESE PART NAMES ARE REFERENCED IN THE INSTRUCTIONS ON PAGE 4.

<b>Description:</b>	Bowl Mounting Bracket
<b>Material:</b>	Stainless Steel

# INSTALLATION OF THE MOUNTING BRACKET

**PLEASE REFER TO THE SPECIFICATION SHEET ON PAGE 3 FOR PART NAMES REFERENCED IN THESE INSTRUCTIONS.**

## STEP 1

Place the mounting bracket on the desired surface, make sure the Ventilation Spacers are facing upwards.

*See Figure 1.*

## STEP 2

Make sure your center connections hole is not bigger than 4 inches or else there will not be enough space for the anchor screws to be installed on the outer lip of the mounting plate. *See Figure 1.*

## STEP 3

Mark where you will insert your anchor screws via the anchor holes on the mounting plate, We recommend using a pilot hole before drilling the anchor screws. The pilot hole should be  $3/16$ " smaller than the anchor bolt to avoid cracking the concrete. *See Figure 1.*

## STEP 4

Place the mounting plate above the anchor holes, put washers on the anchor screws and then anchor the mounting plate by drilling the anchor screws in the anchor holes located on the outer lip of the mounting plate. *See Figure 1.*

## STEP 5

Run your connections straight through the center hole of the mounting bracket.

## STEP 6

Remove the clamping plate and nuts in order to place the bowl on top of the mounting plate.

*See Figure 2.*

## STEP 7

Place the clamping plate on top of the inner hole of the bowl, then tighten the nuts on top of the clamping plate. (Do not cover or caulk the space between the mounting bracket and the bowl as this would cause a ventilation issue.)

*See Figure 2.*

**NOTE: ANCHOR SCREWS ARE NOT SUPPLIED WITH THE MOUNTING BRACKETS.**

FIGURE 1

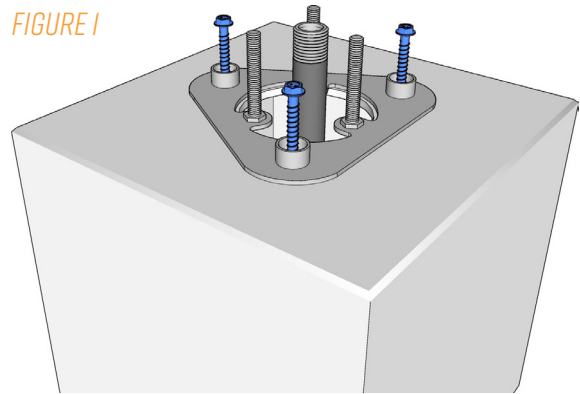

FIGURE 2

